

D-protective cover

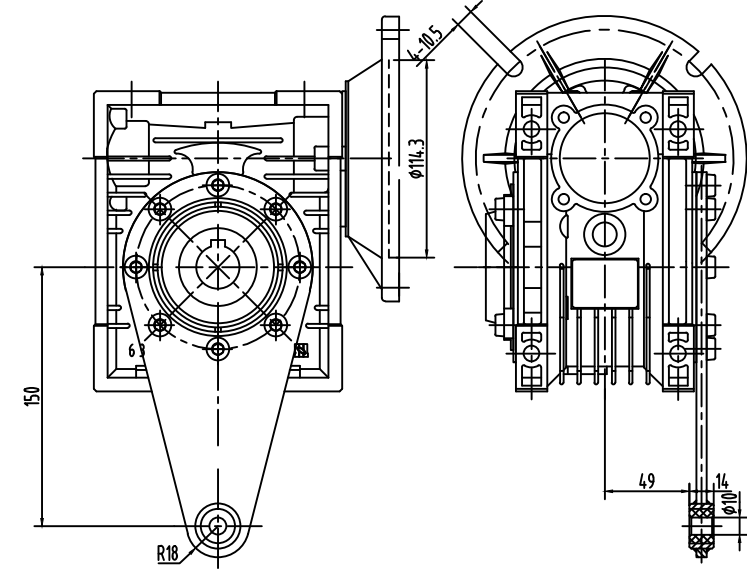

E-torque arm

Motor flange mounting dimensions

Motor flange	Dim	D	M	P	d	BH	BU	E	Q	The hole diameter of shaft UA									
										Ratio i									
										7.5	10	15	20	25	30	40	50	60	80
56C	114.3	149.4	165.1	10.5	18.1	4.78	6	55	15.88										
140TC					24.6	4.78	6	59	22.23										

Output flange mounting dimensions

Dim	KA	KB	KC	KN	KM	KO	KP	KQ	KT	KW
FA	82	10	6	115	150	11	180	142	-	45°
FB	112	10	6	115	150	11	180	140	-	45°
FC	98	11	5	130	165	11	200	-	80	45°
FD	107	11	5	130	115	11	200	-	80	45°
FE	80.5	16.5	6	110	130	11	160	-	-	45°

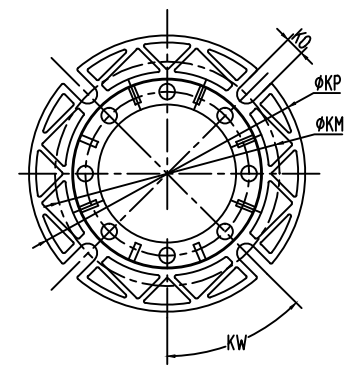
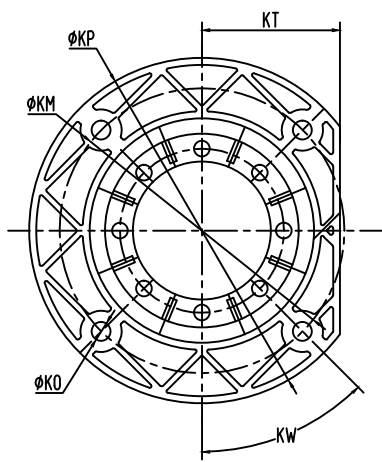
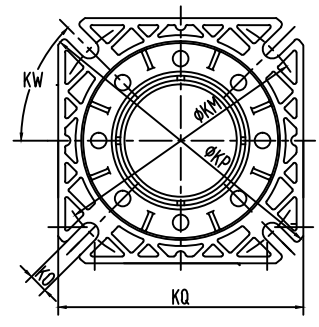
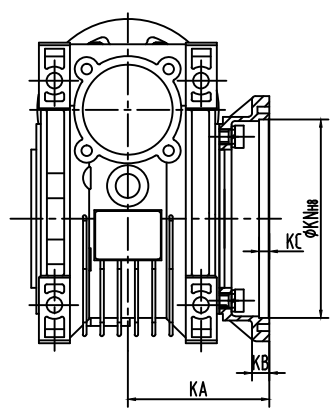

Output flange mounting dimensions

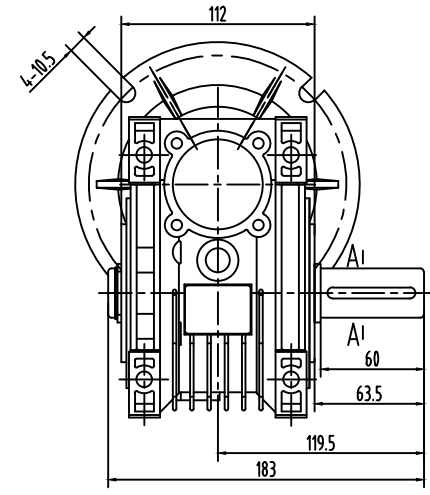

A-single output shaft

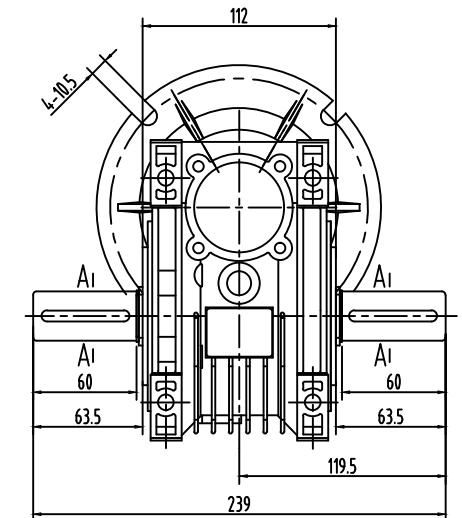
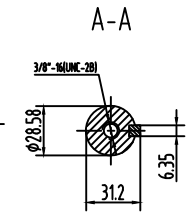

B-doube output shaft



Worm Gear